

ENGINE SPECIFICATIONS		
Configuration	Vertical in-line 6-cylinder	
Induction system	Naturally aspirated	
Combustion system	Spark-ignited	
Cooling system	Water-cooled	
Displacement	6.5 L (397 cubic inches)	
Compression ratio	9:1	
Bore x stroke	4.1 x 4.9 inches (105 x 125 mm)	
Direction of rotation	Counterclockwise	
Approx. wet weight (power unit, G-drive)	2,178 lbs., power unit	1,708 lbs., G-drive
Length (power unit, G-drive)	75.0 inches, P.U.	57.5 inches, Gdrive
Width	39.5 inches, P.U.	35.5 inches, Gdrive
Height	89.1 inches, P.U.	56.4 inches, Gdrive
Fuel type	NG/ wellhead/ LPG/ VPG	

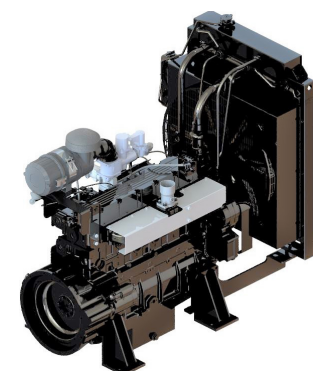
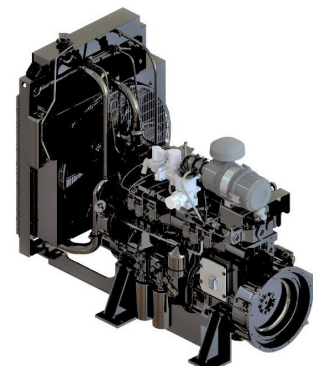

### Power Ratings

50 Hz (1,500 RPM)				
Application	Fuel	kWe	kWm	bHP
Prime	NG	51	57	77
Prime	LPG/VPG	56	62	84
Standby	NG	57	63	85
Standby	LPG/VPG	62	69	93

60 Hz (1,800 RPM)				
Application	Fuel	kWe	kWm	bHP
Prime	NG	57	63	85
Prime	LPG/VPG	63	70	95
Standby	NG	63	70	94
Standby	LPG/VPG	70	78	105

Weight, physical dimensions, and power ratings are for reference only. Final product data may differ slightly.

**NOTE:** kWe calculated using 90 percent alternator efficiency at 0.8 power factor.

Image shown is for illustration purposes only and may not be an exact representation of the final product.

### Features

- EPA-certified stationary/nonroad mobile and emergency standby
- Prime certified operating fuels – pipeline NG, LPG/VPG, and wellhead NG (700–1,600 BTU/ft<sup>3</sup>)
- Standby certified operating fuels – pipeline NG, LPG/VPG
- Single-piece cylinder head
- Stellite valves and hardened seats
- Two valves per cylinder
- Integral oil cooler with twin filter and centrifuge filter
- Cast-iron block
- Forged steel, dynamically balanced and counterweighted crankshaft with hardened journals
- Woodward PG+ engine control system
- Standard canbus interface (SAE J1939)
- Telematics compatible
- Bi-fuel auto switching capable

### ENGINE SPECIFICATIONS

Number of main bearings	7
Removable sleeves	Yes, standard
Ignition system	ECM, smart coil, 6+1 cam
Firing order	1-5-3-6-2-4
Fuel system	ECM, EFR, bi-fuel capable (NG/LPG)
AFR system	ECM, O <sub>2</sub> closed loop, integral 3-way catalyst
Governor	ECM, L-Series actuator
Operating speed range	Prime: 1,200–1,800 RPM Standby: 900–2,200 RPM
Electrical system	12V standard/ 24V optional
Air filter	Dry type
Oil capacity	12 quarts (11.4 L)
Oil cooler	Standard
Coolant capacity	28 quarts (26.5 L)
Fan	Suction or pusher
Flywheel	SAE 11.5
Flywheel housing	SAE 3

### KP6 NA Performance Data

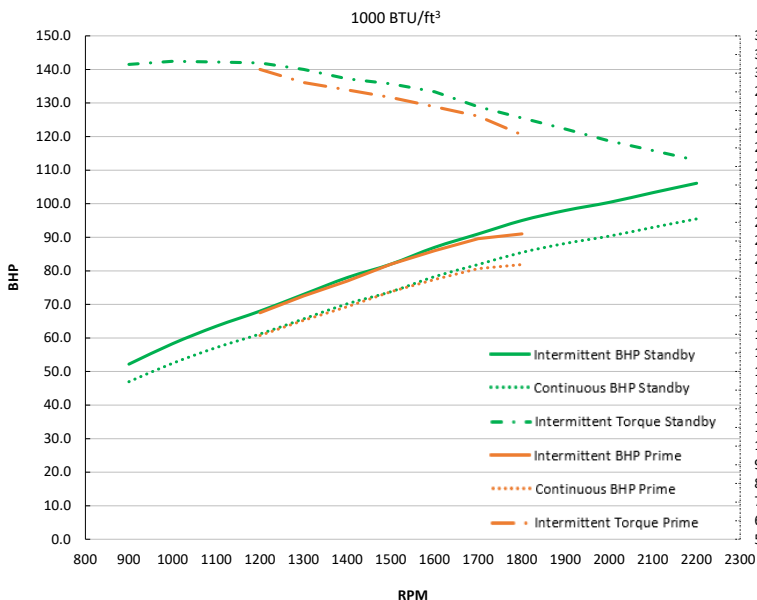

### KP6 NA Fuel Economy

