



**Original Equipment.  
Engineered Solutions.**

# A54E

## EMISSIONS-RELATED INSTALLATION MANUAL

**2021 Installation Instructions  
for A54E Certified Engine**

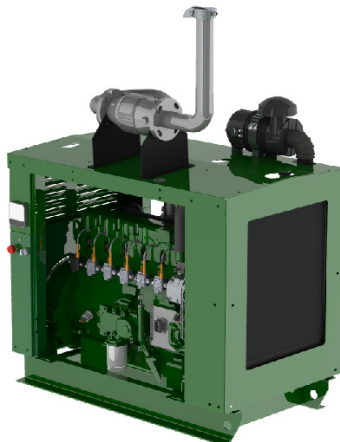

**ARROW ENGINE COMPANY**  
2301 E. Independence St., Tulsa, OK 74110  
[www.arrowengine.com](http://www.arrowengine.com)

©2021  
Arrow Engine Company  
A54E-EIM-SEP2021

# Table of Contents

Important Notice . . . . .	3
U.S. EPA Requirements for Stationary Engines . . . . .	3
Safety Symbols . . . . .	4
Operating Speed Ranges . . . . .	4
Exhaust System and Catalyst Application Guidelines . . . . .	5
Exhaust System Installation Instructions . . . . .	6
Engine and Emissions Labels . . . . .	8
Positive Crankcase Ventilation (PCV) System . . . . .	9
Malfunction Indicator Lamp (MIL) . . . . .	10
Air Filter Requirements . . . . .	10
Fuel System Installation Guidelines . . . . .	11
Check for Gas Leaks . . . . .	12
Spark Plug Gap . . . . .	14
Installation Checklist . . . . .	15

# IMPORTANT NOTICE

## Emission-related Installation Instructions

These instructions provide the final assembler with the information needed to ensure that the engine, catalyst, exhaust system, and gaseous fuel system are installed correctly in the engine's certified configuration.

Arrow's certified Large Spark-Ignited (LSI) 5.4L engine, EPA engine family code MAR-WB05.4A54, is certified for use as a mobile and stationary constant-speed engine only. This engine cannot be used in variable-speed applications.

***Failing to follow these instructions when installing a certified engine in a piece of non-road equipment violates U.S. federal law (40 CFR 1068.105(b)), subject to fines or other penalties as described in the Clean Air Act.***

## U.S. EPA Requirements for Stationary Engines

To ensure emissions compliance of your stationary engine, the U.S. EPA requires you to do one of the following two options:

1. Install and operate your engine as specified in these installation instructions. This is the only option available for mobile engines.
2. If you do not install and operate your stationary engine as specified in these instructions, your engine will be considered a noncertified engine.

In this case, you must:

- Keep a maintenance plan and records of conducted maintenance.
- To the extent practicable, maintain and operate the engine in a manner consistent with good air pollution control practice for minimizing emissions.
- For engines between 100 and 500 HP, conduct an initial performance test within one year of engine startup to demonstrate compliance. Contact your regional EPA office for instructions on how to conduct an initial performance test.

Per section 113 of the U.S. Clean Air Act, failure to abide by these legal requirements can result in fines up to \$30,750 per day.

## Safety Symbols

These are the ISO 8999 symbols that may appear in this publication:



Battery



Electrical hazards



Engine coolant fill level



Engine coolant temperature



Engine oil fill level



Engine oil pressure



Hot surface warning



Warning



Read the manual



No Smoking or flame

## Operating Speed Ranges

The engine set point for the Arrow A54E certified engine must stay between 900 and 1,800 RPM. The actual speed may deviate outside of this range for a short period of time.

**NOTE:** For cyclical load applications, such as pump jack, the load should be balanced such that the total RPM swing throughout the load cycle is less than 100 RPM.

An RPM swing greater than 100 RPM may result in tailpipe emissions exceeding EPA limits for this constant speed engine due to the frequency and magnitude of transient fueling demands. See Table 1 for clarification.

Speed Set Point RPM	Observed RPM Maximum @ Load Rejection RPM	Observed RPM Minimum @ Load Rejection RPM	Total RPM Swing RPM	Result
1,500	1,600	1,400	200	Not acceptable
1,500	1,550	1,450	100	Acceptable



**Table 1.** RPM Swing Definition

# Exhaust System and Catalyst Application Guidelines

Catalyst DDC70031 must be used with the Arrow A54E certified engine.

These guidelines are for the equipment package designer to follow to ensure that the catalyst will operate correctly and will comply with emissions regulations for its design life. Each guideline should be verified on the prototype package.

1. To operate efficiently and have long life, the internal catalyst temperature **MUST** stay within the range of 650°F to 1,400°F (343°C to 760°C) at all operating conditions except for low idle. The exhaust temperature immediately downstream of the catalyst is a good indication of the internal catalyst temperature. The post-cat O<sub>2</sub> port can be used to measure the cat-out temperature for test purposes.
  - If the catalyst is cooler than the specified temperature range, it will not operate efficiently and may not comply with emissions regulations.
  - If the catalyst temperatures are too cool, exhaust tape or an exhaust blanket upstream of the catalyst can be used to increase the exhaust temperature at the catalyst inlet.
  - If the catalyst is hotter than the specified temperature range, the catalyst will not operate efficiently and may be permanently damaged.
  - If the catalyst is too hot, verify that all cylinders are firing correctly and that unburned fuel is not reaching the catalyst. If the engine is operating correctly and the catalyst is still too hot, it may be necessary to move the catalyst farther downstream on the exhaust pipe.
2. Under normal operating conditions, the catalyst will remain hot for a long time after the exhaust pipe has cooled. Under engine misfire conditions, catalyst surface temperatures greater than 1,560°F (850°C) can be expected.



The equipment packager is advised to guard against the high catalyst surface temperatures with a heat shield and/or warning.

3. Catalyst vibration levels must be less than 5 g's in all three axes (x, y, and z) under all engine operating conditions.  
Vibration levels in excess of 5 g's at a single speed-load point (resonance condition) can cause catalyst damage and failure.
4. The maximum allowable exhaust back pressure measured between the catalyst and exhaust manifold is 20 in H<sub>2</sub>O (5 kPa). Pressures greater than this will cause reduction in available engine power and may cause exhaust leakage at the manifold flange.

# Exhaust System Installation Instructions

These installation instructions must be strictly observed and verified on each engine installation. Failure to observe these requirements will void the catalyst warranty and may result in EPA fines of up to \$30,750 per day.

These instructions are intended to minimize potential instances that may compromise the mechanical durability of the product as a result of:

- Engine vibration
- Thermal expansion and contraction of exhaust system
- Shock loads during operation of the equipment
- Improper mounting of the catalyst unit

Please note that the catalytic converter (catalyst) is much heavier and more fragile than a regular muffler and it therefore it must be supported properly.

These installation instructions require the following components to be incorporated into the complete assembly to ensure the product meets its design life. Note that some of these instructions represent recommended practices and each exhaust application must be evaluated to meet the specific guidelines regarding temperature and vibration limits.

1. No catalyst substitutes are allowed. The EPA emissions certifications specify that only the catalyst listed in Table 2 can be used.
2. As a guideline, the inlet of the catalyst should be located 42–72 inches from the exhaust manifold outlet. The actual distance is determined by testing the exhaust temperature out of the catalyst. Exhaust temperature testing will be required for each application/exhaust configuration to ensure the temperature falls in the acceptable range prior to application approval.
3. Stainless shim exhaust manifold gaskets are strongly recommended.
4. A 3-inch flexible coupling is recommended between the engine and catalyst to isolate the catalyst from the engine's torsional vibration.
5. The exhaust pipe must be supported four inches upstream and downstream of the catalyst.
6. Vibration isolators are required on the support brackets to isolate the catalyst from engine/chassis vibration.
7. The catalytic converter should not be used to support any loads from upstream or downstream components or piping.
8. Band clamps, flanges or welds are required at all exhaust pipe and catalyst-pipe junctions. All junctions must be leak-tight.

9. The exhaust pipe must extend 12 inches past the oxygen sensor located at the catalyst outlet
10. When the pre-cat and post-cat oxygen sensors are mounted in horizontal pipe, the sensors must be in the top half of the pipe to avoid being immersed in water. Direct contact with liquids may cause the sensors to fail.
11. EPA requires that (CFR 40 1048.205 (v)) the exhaust pipe be configured so that a 20 cm (8-inch) extension can be easily added to the end of the exhaust pipe for measuring emissions in the field. For example, if a rain cap is used, it must be removable. If it is not feasible to add an extension, add a 1/4-inch sample port to the exhaust pipe after the catalyst and at least 20 cm (8 inches) before the end of the pipe.
12. Lightly coat the threads of the pre-cat and post-cat oxygen sensors with O<sub>2</sub>/catalyst safe anti-seize compound, if not coated by the sensor manufacturer. Tighten the oxygen sensors to 37 ft.-lbs.
13. A rain cap or 90-degree bend is required if the tail pipe is vertical and can collect water.
14. The entire exhaust system must be checked for leaks by sealing one end of the exhaust pipe and applying 3 psig air pressure to the other end. Apply leak detector or a soapy water mixture to all joints and fittings. There must be no leaks that can be heard or felt. Slow bubble leaks are OK.

Component	Quantity	Approved Part Number Substitutes Must Be Approved by the MOR
Catalyst	1	DDC70031
Exhaust manifold	1	217142

**Table 2.** Arrow 5.4L Exhaust System Components

# Engine and Emissions Labels

The EPA requires that the following label must be visible.

If you install the engine in way that makes the engine emission control information label difficult to read during normal engine maintenance, you must place a duplicate label on the equipment, as described in 40 CFR 1068.105.

1. U.S. EPA emissions label
2. Engine label with engine part number, serial number, and date of manufacture.

IMPORTANT ENGINE INFORMATION	EMISSIONS CONTROL INFORMATION
<p>THIS ENGINE COMPLIES WITH U.S. EPA REGULATIONS FOR 2021 NONROAD AND STATIONARY ENGINES. THIS ENGINE IS CERTIFIED TO OPERATE ON COMMERCIAL LPG AND PIPELINE-QUALITY NATURAL GAS. THIS ENGINE IS ALSO CERTIFIED TO OPERATE ON NON-PIPELINE NATURAL GAS WITH A METHANE CONTENT OF AT LEAST 45% BY VOLUME AND ENERGY CONTENT OF 700 -1600 BTU PER SCF. NO ADJUSTMENTS ARE REQUIRED. USE IN CONSTANT-SPEED APPLICATIONS ONLY.</p> <p>Engine Family: MARWB05.4A54 Engine Displacement: 5.4 L Spark Plug Gap: 0.025 in (0.635 mm)</p>	<p><u>Nonroad Emission Standards (g/kW-hr)</u> 2.7 HC+NOx, 4.4 CO</p> <p><u>Stationary Emission Standards (g/kW-hr)</u> 2.7 HC+NOx, 4.4 CO</p> <p>Exhaust Emission Control: ECM, MIX, HO2S, TWC</p> 



# Positive Crankcase Ventilation (PCV) System

EPA specifies that “Crankcase emissions may not be discharged directly into the ambient atmosphere from any engine throughout its useful life.”

The A54E uses a closed crankcase ventilation system as shown in Figure 1. Manifold vacuum is applied to the PCV valve (Item No. 13) to collect blowby gases and send them back to the intake system. Fresh air is supplied to the crankcase via the crankcase breather (Item No. 9).

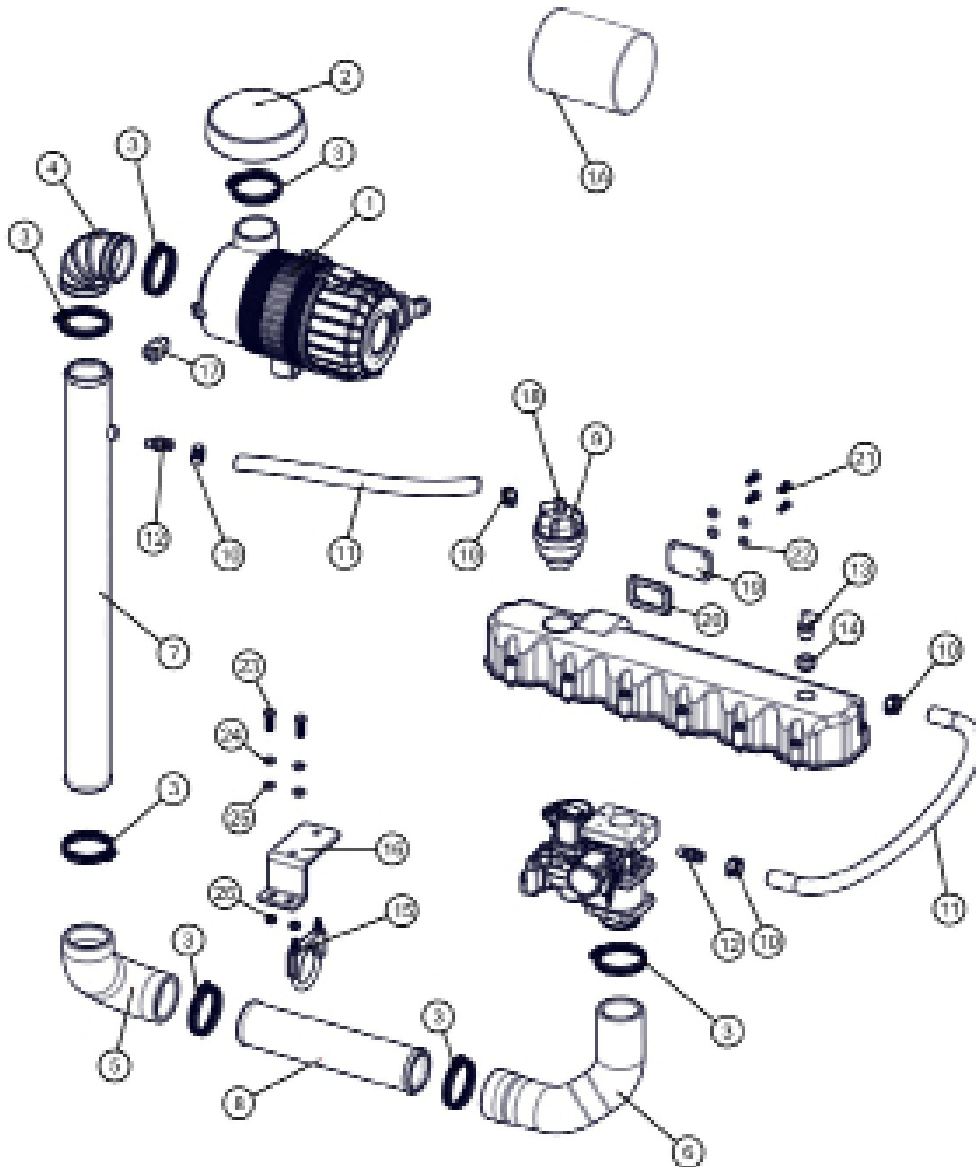

Figure 1

# Malfunction Indicator Lamp (MIL)

## EPA Malfunction Indicator Lamp (MIL) Requirements:

1. Use a malfunction-indicator lamp (MIL).
2. The MIL must be readily visible to the operator; it may be any color except red.
3. When the MIL lights up, it must display “Check Engine” or “Service Engine Soon” or be appropriately labeled.
4. You may use sound in addition to the light signal.

## Air Filter Requirements

1. All engines are required to have an air filter; otherwise, the engine warranty will be voided. The filter should be configured so it does not ingest unnecessarily hot air (over 130°F), rain, or moisture.
2. The air pressure drop across the air filter must not exceed:
  - Clean filter: 5 in H<sub>2</sub>O
  - Dirty filter: 15 in H<sub>2</sub>O
3. The approximate maximum engine air flow for Arrow LSI-certified engines is as follows:
  - 5.4 L - 125 SCFM

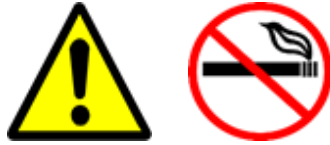

## Fuel System Installation Guidelines

### Fuels

Natural gas and LPG are combustible gases, and can be explosive if leaked and contained in a confined area. Keep cigarettes and all other flame sources away from these areas.

Depending on your engine and fuel system configuration, your engine is designed to run on natural gas, liquid LPG, or vapor LPG. The fuel requirements for each are discussed in this section.

### Natural Gas

Your engine is certified to run on natural gas of pipeline-quality and most grades of nonpipeline quality. Specifically, your engine is certified to run on natural gas that has at least 45% methane content by volume AND an energy content of 700 to 1,600 Btu per SCF. If your natural gas supply does not meet both of these specifications, your engine is operating as a noncertified engine. See U.S. EPA Legal Requirements section of this manual.

Arrow Engine requires that the natural gas comply with the following specifications; otherwise, the fuel system and engine warranties may be void.

- Hydrogen: < 500 mg/10 kWh
- Chlorine and fluorine compounds (typically chlorofluorocarbons): < 100 mg/10 kWh
- Silicon: < 5 mg/10 kWh
- Ammonia: < 50 mg/10 kWh
- Oil or hydrocarbons in liquid (mist form): < 5 mg/10 kWh
- No liquid water is permitted at the inlet of the engine-mounted fuel system

### Liquefied Petroleum Gas

To maintain emissions compliance and the engine warranty, use commercial-grade HD-10 or better LPG. Liquid LPG is drawn off the bottom side of an LPG tank or cylinder and is a liquid until it has passed through the regulator/vaporizer, at which point it is vaporized to a gas. If you connect vapor LPG to a liquid LPG fuel system, you may starve the engine for fuel, causing it to produce low power and excessive emissions.

Vapor LPG is drawn off of the top side of an LPG tank or cylinder. Only a fuel pressure regulator (not a vaporizer) is required for vapor LPG. However, the LPG tank/cylinder must have enough internal surface area to vaporize (boil) LPG at the rate required by the engine.

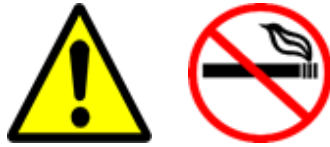

## Check for Gas Leaks

Natural gas and LPG are combustible gases, and can be explosive if leaked and contained in a confined area. Keep cigarettes and all other flame sources away from these areas.

If you can hear a fuel leak, shut off the fuel supply at the source immediately and fix the leak or have it serviced. Check the entire fuel supply line from the cylinder/tank to the engine for leaks with leak detect or a soapy water bubble mixture anytime the fuel supply line is worked on. Fuel leaks should also be checked as part of the regular engine maintenance.

All fuel hose and connections must be leak tight! Use fuel hose, connectors, and sealants specified for the fuel type. Use leak detect or a soapy water mixture to check for leaks. All fuel leaks must be eliminated!

### Inspection

1. If you can hear a fuel leak, shut off the fuel supply at the source immediately and fix the leak or have it serviced.
2. If there are no audible leaks, spray the fuel line up to the lock-off valve with a soapy water mixture. A stream of bubbles indicates leak sources.
3. Tighten fittings and clamps as needed to eliminate slow leaks.
4. Start the engine.
5. Check the fuel supply line from the lock-off valve to the engine with a soapy water mixture.
6. If any fuel line components (hoses, pipe, fittings, etc.) must be replaced, first bleed the fuel out of the line by shutting off the gas supply at the source with the engine running at idle. Wait for the engine to stop before disassembling the fuel line.

Arrow engines are certified to operate on the following fuel types:

- Pipeline-quality natural gas (natural gas from a pipeline having at least 70% methane content or 950–1,100 Btu/ft<sup>3</sup> energy content).
- Nonpipeline quality natural gas (wellhead gas) having at least 45% methane content and 700–1,600 Btu/ft<sup>3</sup> energy content.
- Commercial LPG, grade HD-10 or better.

Stationary engines (not constant-speed mobile engines) may be operated on other fuel types, but are considered noncertified engines. See U.S. EPA Requirements for Stationary Engines section of this manual for more information.

Figure 2 shows the fuel system assembly (electronic fuel control valve and air valve carburetor) used on Arrow LSI-certified engines. See following page.

Figure 3 is a block diagram of the emissions control system used on Arrow LSI-certified engines.

The requirements for the fuel supply to Arrow LSI-certified engines are as follows:

- Fuel supply pressure to the fuel system inlet must be **8–16 in H<sub>2</sub>O (2–4 kPa)**.
- If natural gas and vapor LPG supply pressure is higher than 16 in H<sub>2</sub>O (4 kPa) the packager must install a primary pressure regulator upstream of provided fuel system (not provided with system) to meet the above pressure requirements.
- A 10-micron fuel filter with 99% efficiency is strongly recommended (not provided with system). Failure to properly filter the fuel may cause damage or plugging to fuel system components and void the warranty.

- The following fuel filters are recommended:

Raw natural gas: Oxion, Inc. Model M150

Vapor LPG and pipeline natural gas: Maxitrol Model GF60-1-88

- All low-pressure fuel lines should be 1-inch ID and free from sharp bends or kinks.
- All pipe threads in the fuel system should be sealed with thread sealant specified for the fuel type (NG and/or LPG).
- All fuel system components should be properly supported with brackets and isolated from severe (> 5 g) vibration.
- All fuel system components, fuel lines, and electrical wiring should be a minimum of 12 inches from exhaust system components and properly shielded from direct radiant heat. The final package should provide air circulation around fuel system components to prevent overheating.
- Installation of a manual shut-off valve at the fuel supply source is strongly recommended to allow the fuel to be shut off when the engine is being serviced.

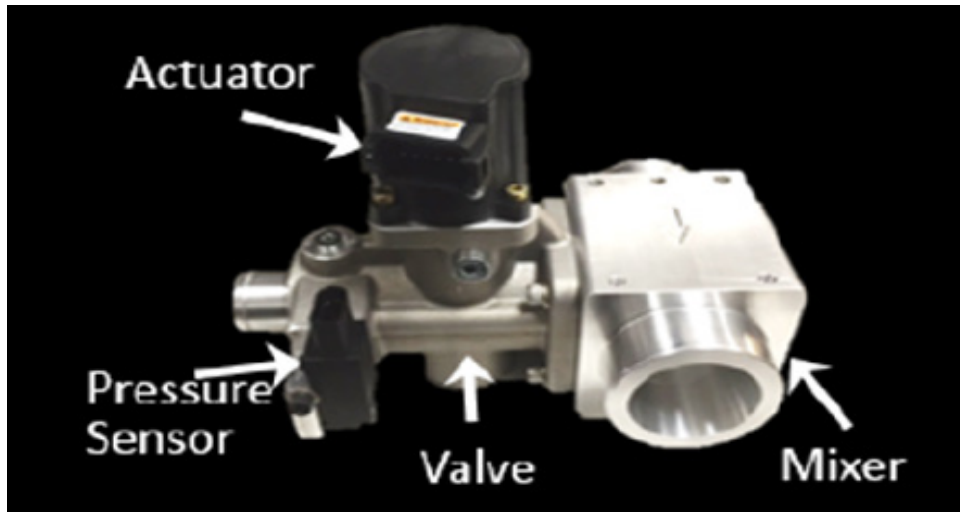

**Figure 2.** Fuel System Assembly for Arrow LSI engines

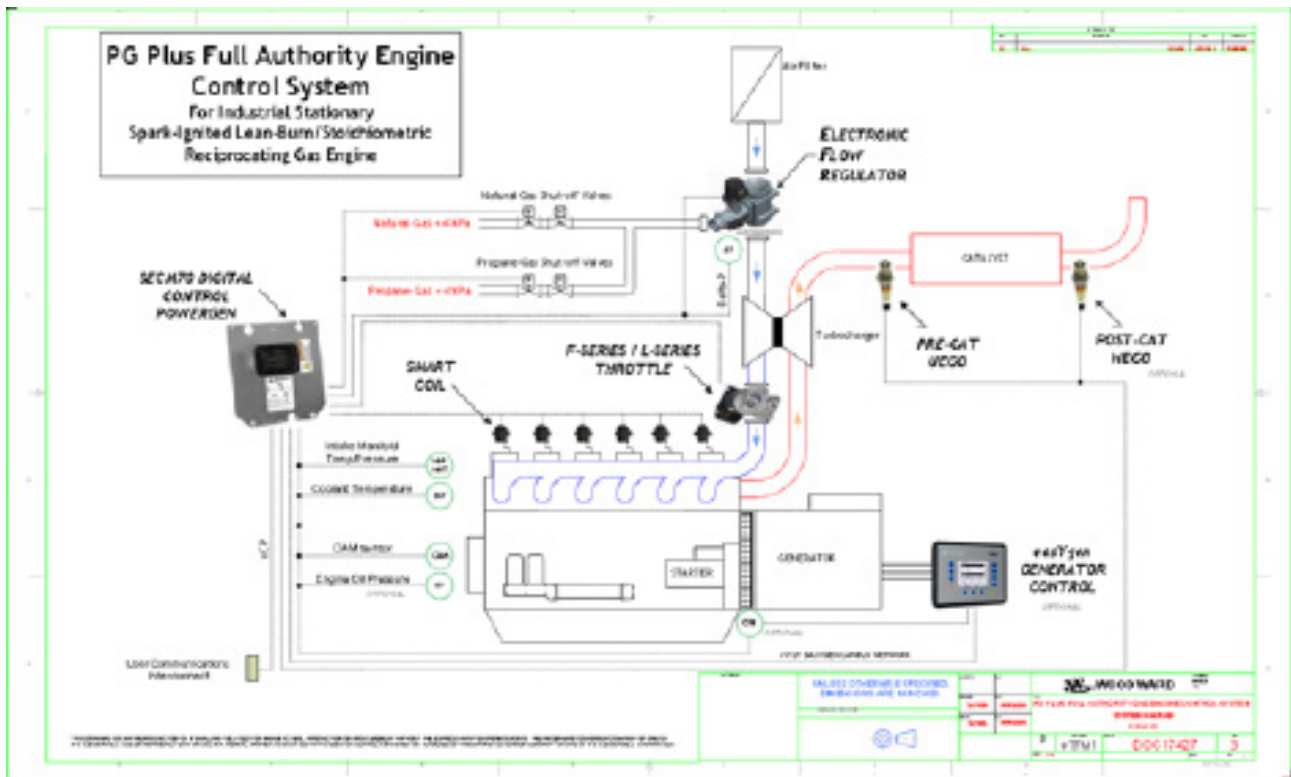

**Figure 3.** NG/LPG Bi-fuel Engine Control System for Arrow LSI engines

## Spark Plug Gap

Spark plug gap: 0.025 inch (0.635 mm)

Ignition timing is not adjustable.

# Emissions-related Installation Checklist

**NOTE:** The emissions-related installation design (catalyst location and mounting, vibration levels, etc.) is verified during the Application Review.

The Application Review must be completed prior to production release of the application to ensure durability and warranty consideration.

Table 3 is a checklist to be used during the package design and final assembly of each production unit. Incorporate this checklist into your design and assembly processes.

Emissions-related Installation Checklist		Page	Package Designer		Final Assembler	
			Yes	No	Yes	No
1	Engine speed within certified operating range	4				
2	Catalyst outlet temps remain between 650°F to 1,400°F (343°C to 760°C) under all operating conditions except low idle	5				
3	Catalyst vibration levels less than 5 g's in all 3 axes	5				
4	Exhaust back pressure is acceptable (< 20 in H <sub>2</sub> O under all operating conditions)	5				
5	Catalyst shielded from human contact and/or warning is visible	5				
6	Exhaust band clamps installed and tightened	6				
7	Catalyst supported within 4 inches upstream and downstream	6				
8	Flexible coupling installed between the engine and catalyst	6				
9	Vibration isolators used on catalyst supports	6				
10	Pre-cat and Post-cat oxygen sensors in the top half of horizontal exhaust pipe	7				
11	Certified catalyst part number is used	7				
12	Rain cap installed	7				
13	Can a 20 cm (8-in) extension be easily added to the end of the exhaust pipe for in-field emissions testing?	7				
14	Threads of oxygen sensors lightly coated with O <sub>2</sub> /catalyst safe anti-seize compound (if not coated by sensor manufacturer)	7				
15	No exhaust leaks between the engine and catalyst	7				
16	Engine and emissions labels installed and visible	8				
17	PCV system plumbed as specified	9				
18	MIL is installed, not red, labeled, and operable	10				
19	Specified air filter is installed	10				
20	Fuel supply configured per guidelines	11				
21	Fuel system is leak-tight	12				
22	Spark plug gap is per specification	14				

Table 3

# ENGINES

<b>C-SERIES</b>	C-46	C-66	C-96	C-106
	<b>A-SERIES</b>	A32	A42	A54E A54
				A62 A62 Turbo A62 Genset

# COMPRESSION PRODUCTS

Compressor Frames VRC-2 VRS-2 VRS-4	CNG Compressor Frames and Packages VRC-CNG	Vapor Recovery Units VRU-1 VRU-2	Gas Lift Packages Electric HP Gas Engine (VR, A-Series, CAT)	Custom Compression Packages
--	---	---	---	-----------------------------------

# GAS PRODUCTS

Coalescers	ASME Code Vessels
------------	-------------------

# REPLACEMENT PARTS

<b>Waukesha</b>	145G/F817	140G/F554	F18	H24	WAK/1197
-----------------	-----------	-----------	-----	-----	----------

